

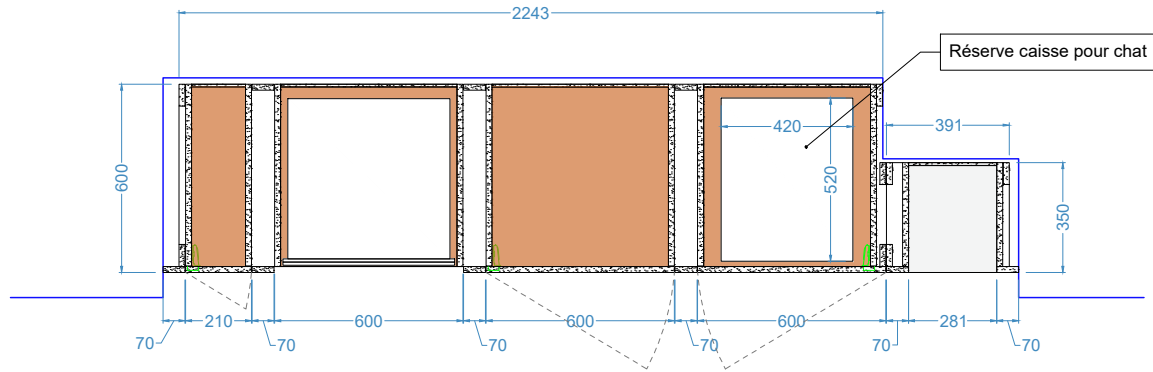

PLAN

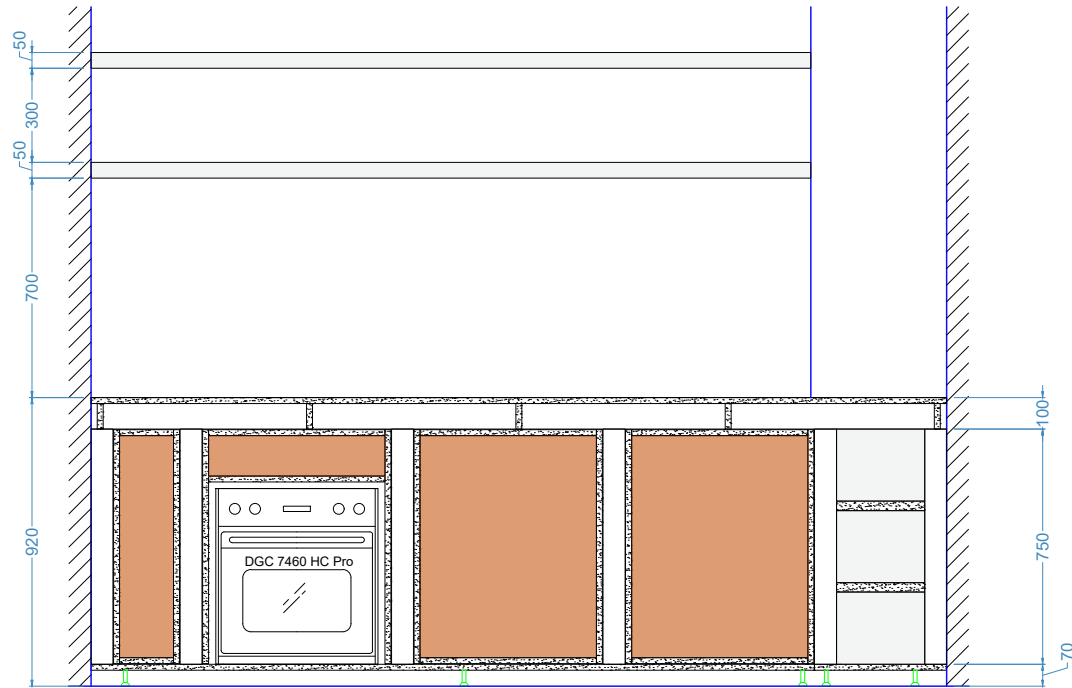

Elevations interieures



GENERAL NOTES.

- Interieur:  
 EGGER - Nude  
 terracotta U830 ST9
- Exterieur:  
 Bois massif aboté
- Structure exterieur  
 Finition béton ciré

LOT2 SUMMER KITCHEN



Nom du Projet	
Adresse	

Designation / Type	
Lot	02
Date	17/05/2023
Page	2.2

REVISIONS	
Rev.	Date
Déssinateur	









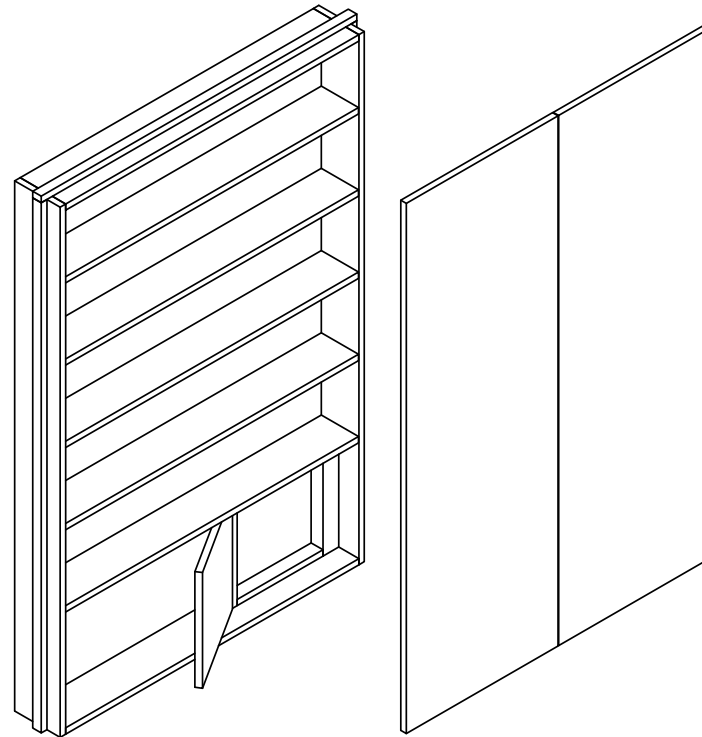

GENERAL NOTES.

interieur:  
EGGER - Vert sapin  
U606 ST9



exterieur:  
MDF Hydrofuge  
à peindre tapissé



LOT3 WC GEBERIT UNIT



Nom du Projet	
Adresse	

Designation / Type	
Lot	03
Date	17/05/2023
Page	3.3

REVISIONS	
Rev.	Date
Déssinateur	

PLAN

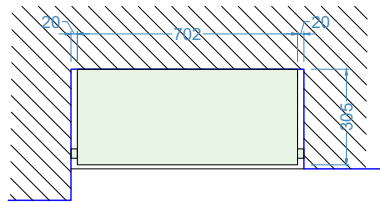

Elevations exterieures

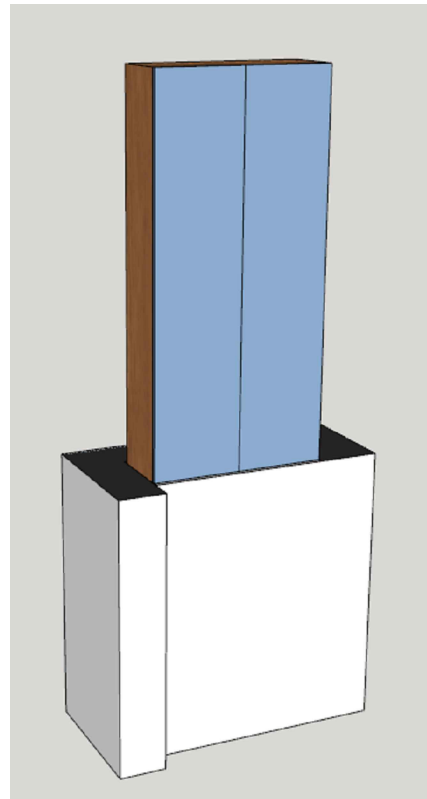
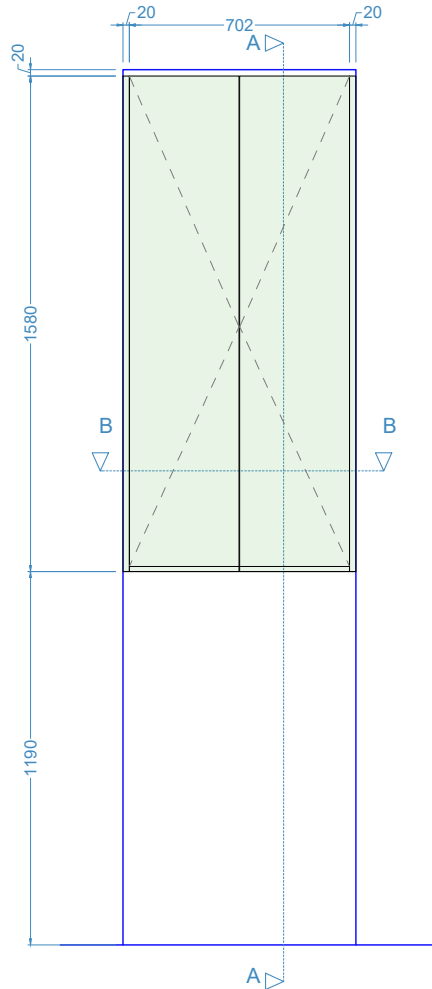

GENERAL NOTES.

- interieur:  
EGGER Rouge   
bordeaux - U311 ST9
- exterieur:  
Medium hydrofuge   
à peindre tapissé

LOT6 WC GEBERIT UNIT



Nom du Projet	
Adresse	

Designation / Type	
Lot	06
Date	17/05/2023
Page	6.1

REVISIONS	
Rev.	Date
Déssinateur	



















PLAN

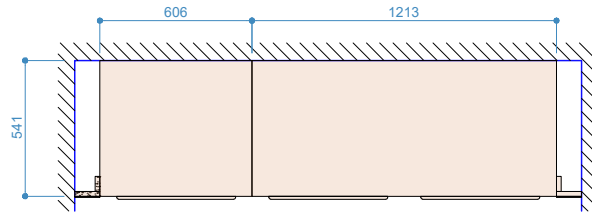

Principe des cadres rapportés

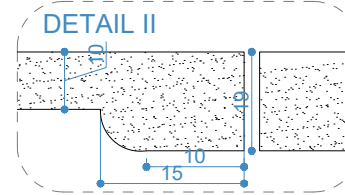

Elevations exterieures

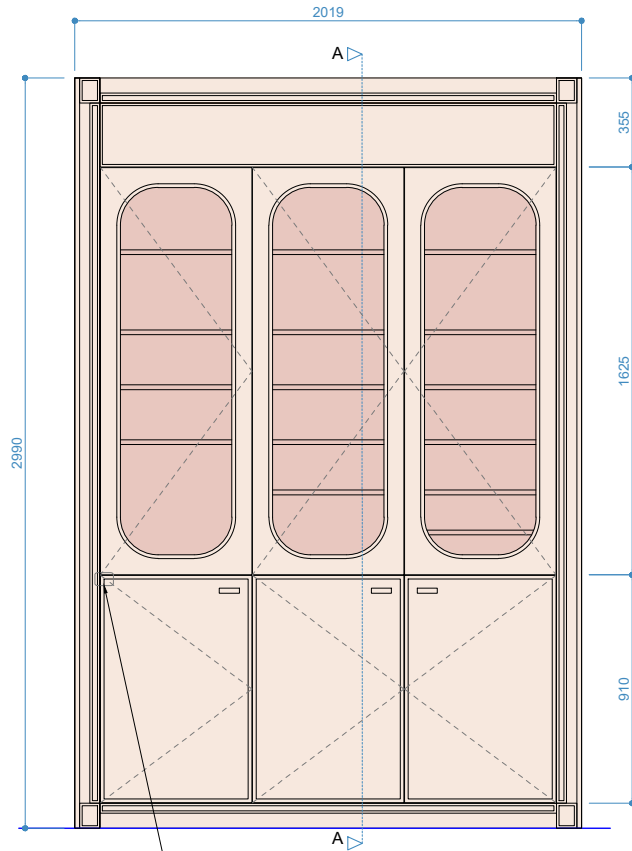

Detail I



GENERAL NOTES.

interieur:  
EGGER - Rouge indien  
U390 ST9 - effet LAQUE

exterieur:  
Chêne Moyen - 50%  
d'eau

LOT8 LISA DRESSING

**Plac'Art**  
Menuiserie - Agencement

Nom du Projet	
Adresse	

Designation / Type	
Lot	08
Date	17/05/2023
Page	8.7

REVISIONS	
Rev.	Date
Déssinateur	





PLAN

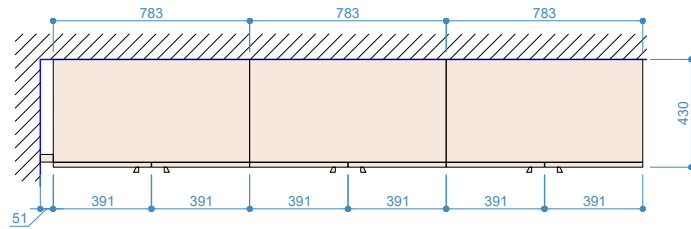

Elevations exterieures

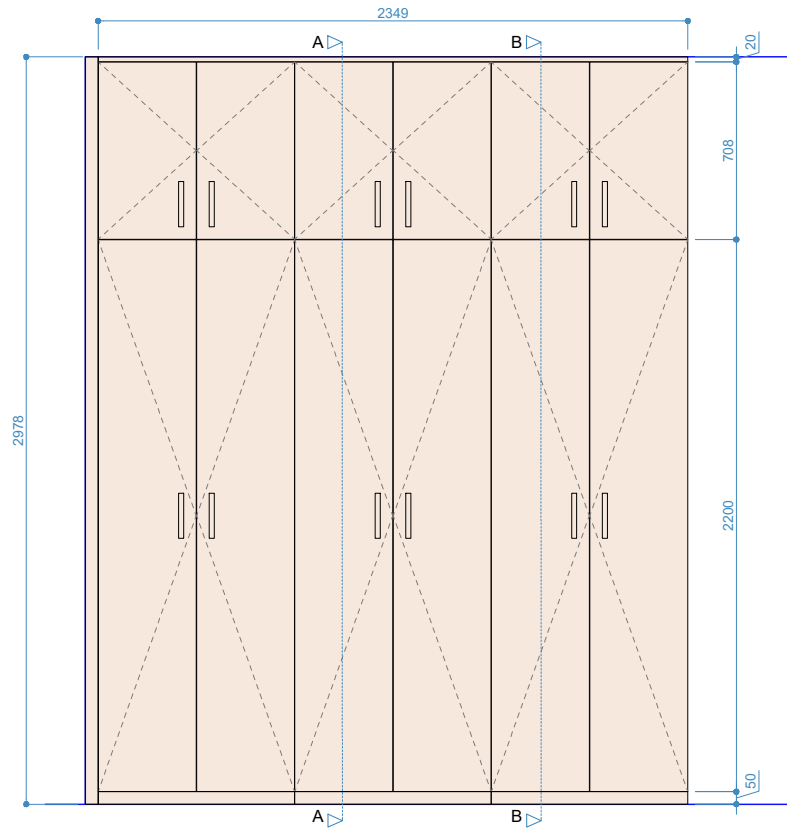

GENERAL NOTES.

- interieur:  
EGGER Gris carbone - U968 ST9
- exterieur:  
Chêne Moyen - 50% d'eau
- Medium hydrofuge à peindre

LOT9 MARIUS BEDROOM

**Plac'Art**  
Menuiserie - Agencement

Nom du Projet	
Adresse	

Designation / Type	
Lot	09
Date	17/05/2023
Page	9.1

REVISIONS	
Rev.	Date
Déssinateur	





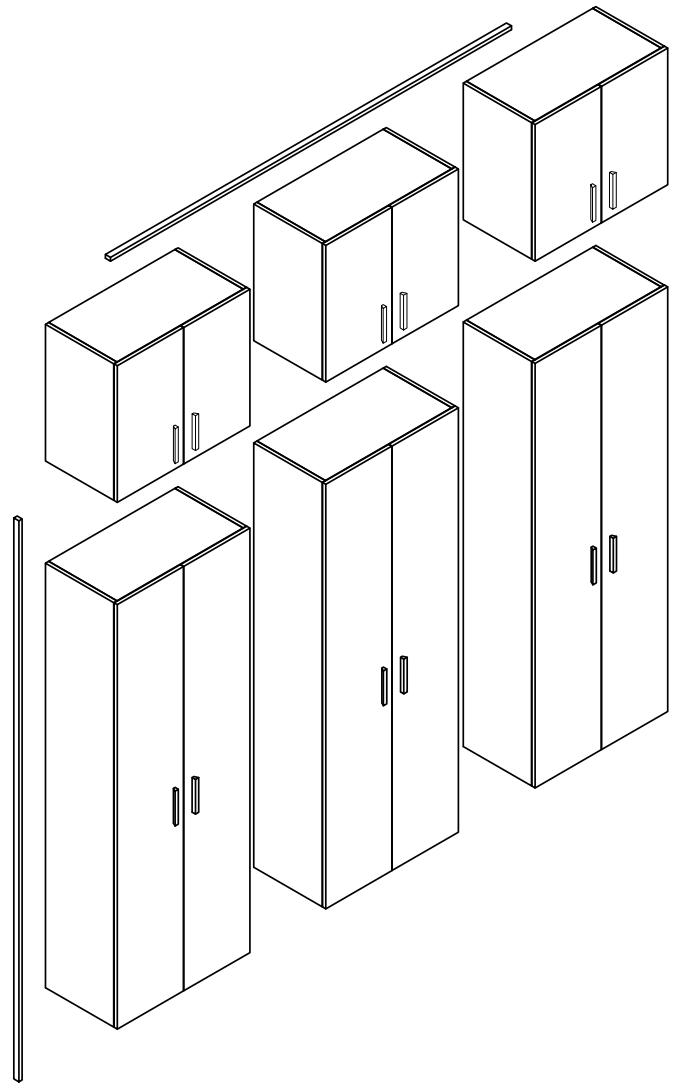

GENERAL NOTES.

interieur:  
EGGER Gris carbone  
- U968 ST9



exterieur:  
Chêne Moyen - 50%  
d'eau



Medium hydrofuge  
à peindre



LOT9 MARIUS BEDROOM



Nom du Projet	
Adresse	

Designation / Type	
Lot	09
Date	17/05/2023
Page	9.3

REVISIONS	
Rev.	Date
Déssinateur	



### Elevations exterieures

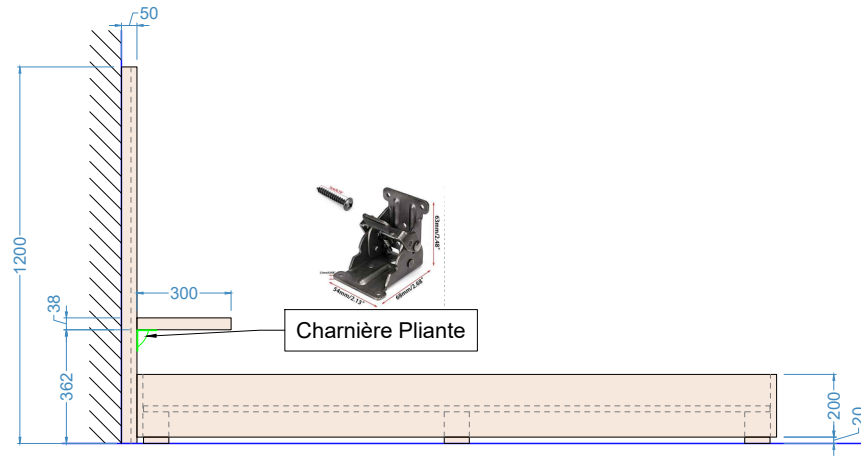

### Coupe A-A

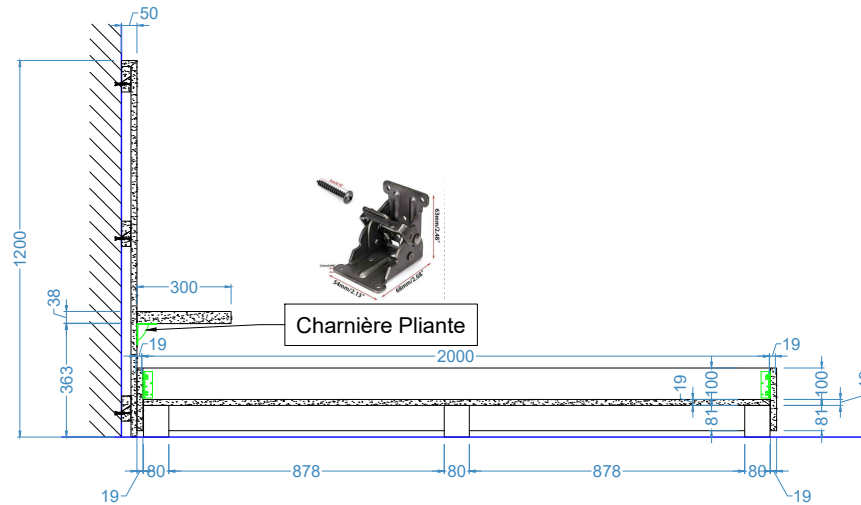

### GENERAL NOTES.

- interieur:  
EGGER Gris carbone - U968 ST9
- exterieur:  
Chêne Moyen - 50% d'eau
- Medium hydrofuge à peindre

LOT9 MARIUS BEDROOM

**Plac'Art**  
Menuiserie - Agencement

Nom du Projet	
Adresse	

Designation / Type	
Lot	09
Date	17/05/2023
Page	9.5

REVISIONS	
Rev.	Date
Déssinateur	

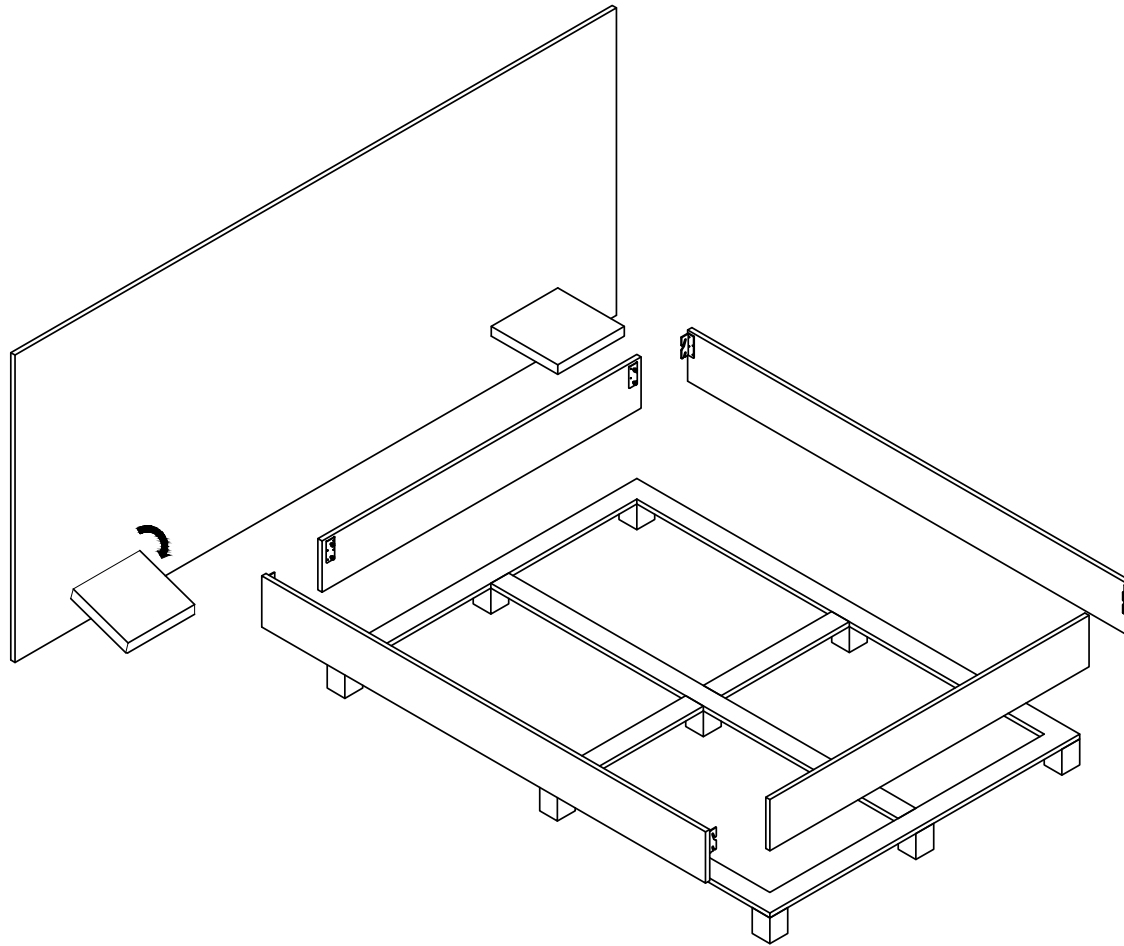

GENERAL NOTES.

interieur:  
EGGER Gris carbone  
- U968 ST9



exterieur:  
Chêne Moyen - 50%  
d'eau



Medium hydrofuge  
à peindre



LOT9 MARIUS BEDROOM



Nom du Projet	
Adresse	

Designation / Type	
Lot	09
Date	17/05/2023
Page	9.6

REVISIONS	
Rev.	Date
Déssinateur	







PLAN

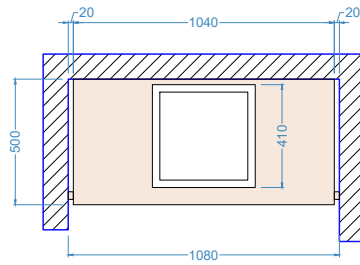

Elevations exterieures

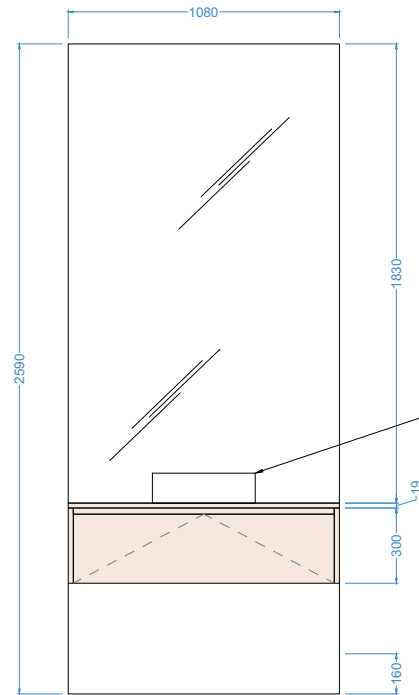

Vasque Tikamoon  
vasque en marbre Slats  
dark Grey

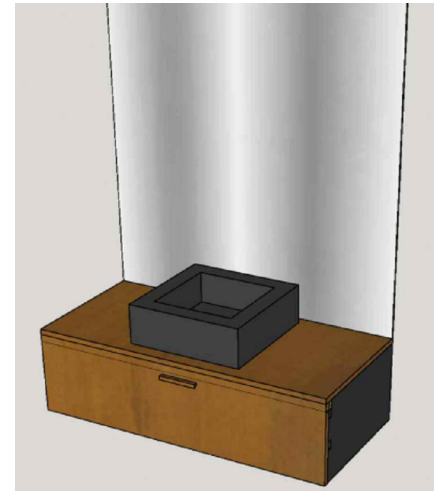

GENERAL NOTES.

interieur:  
EGGER Gris carbone - U968 ST9

exterieur:  
Chêne Moyen - 50% d'eau

LOT10 VANITY UNIT



Nom du Projet	
Adresse	

Designation / Type	
Lot	10
Date	17/05/2023
Page	10.1

REVISIONS	
Rev.	Date
Déssinateur	



PLAN

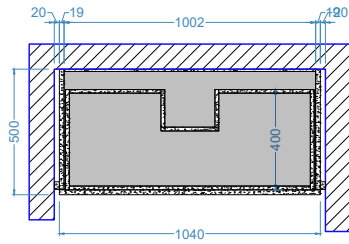

Elevations interieures

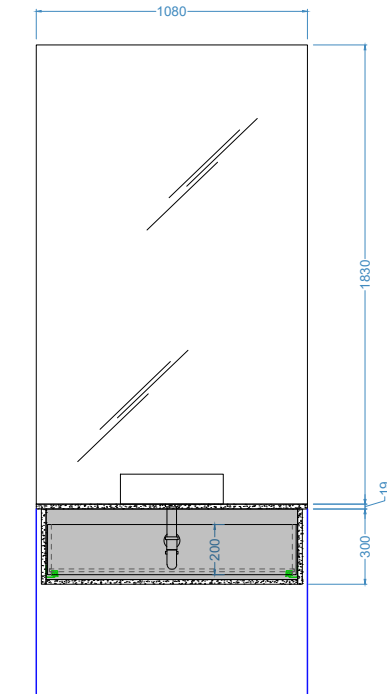

Coupe A-A

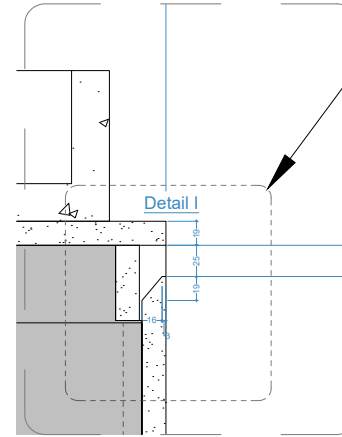
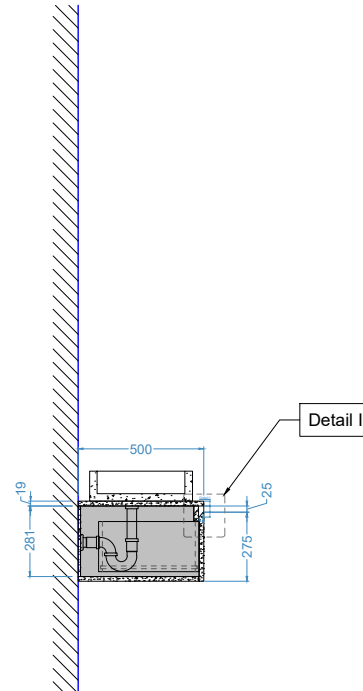

GENERAL NOTES.

- interieur:
  - EGGER Gris carbone
  - U968 ST9
- exterieur:
  - Chêne Moyen - 50% d'eau

LOT10 VANITY UNIT



Nom du Projet	
Adresse	

Designation / Type	
Lot	10
Date	17/05/2023
Page	10.2

REVISIONS	
Rev.	Date
Dessinateur	

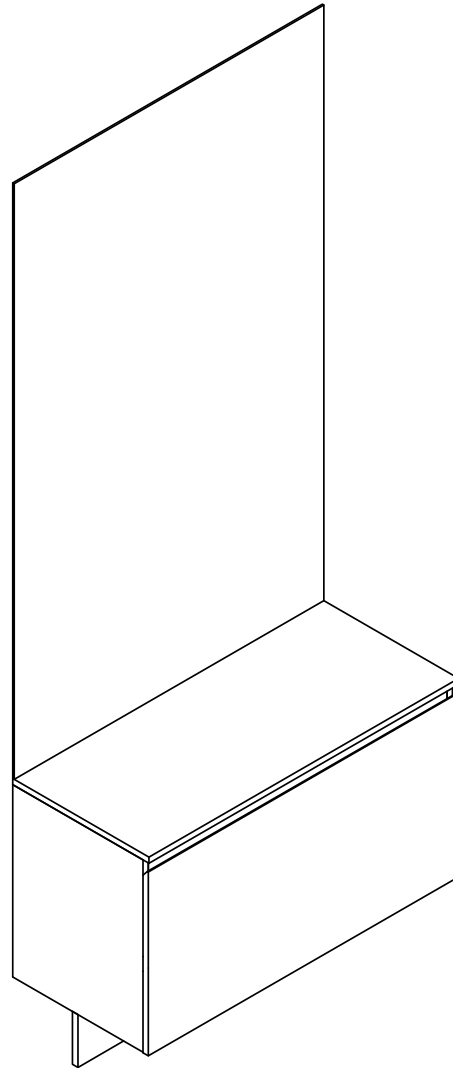

GENERAL NOTES.

interieur:  
 EGGER Gris carbone - U968 ST9

exterieur:  
 Chêne Moyen - 50% d'eau

LOT10 VANITY UNIT



Nom du Projet	
Adresse	

Designation / Type	
Lot	10
Date	17/05/2023
Page	10.3

REVISIONS	
Rev.	Date
Dessinateur	











### Elevations exterieures

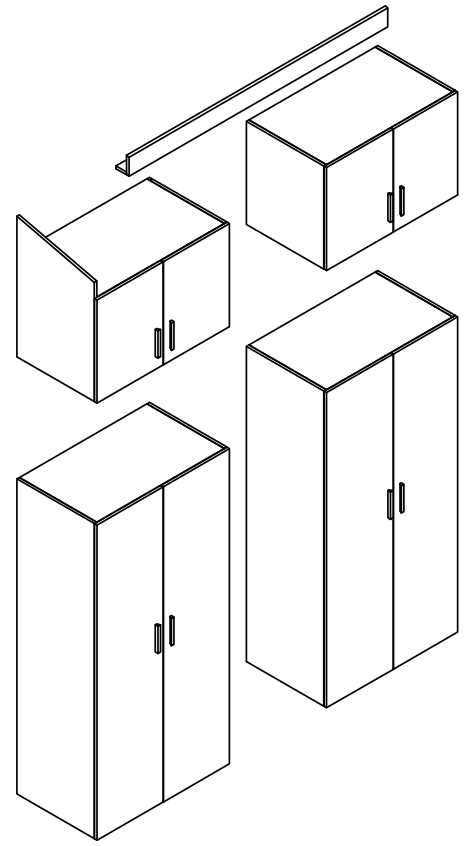
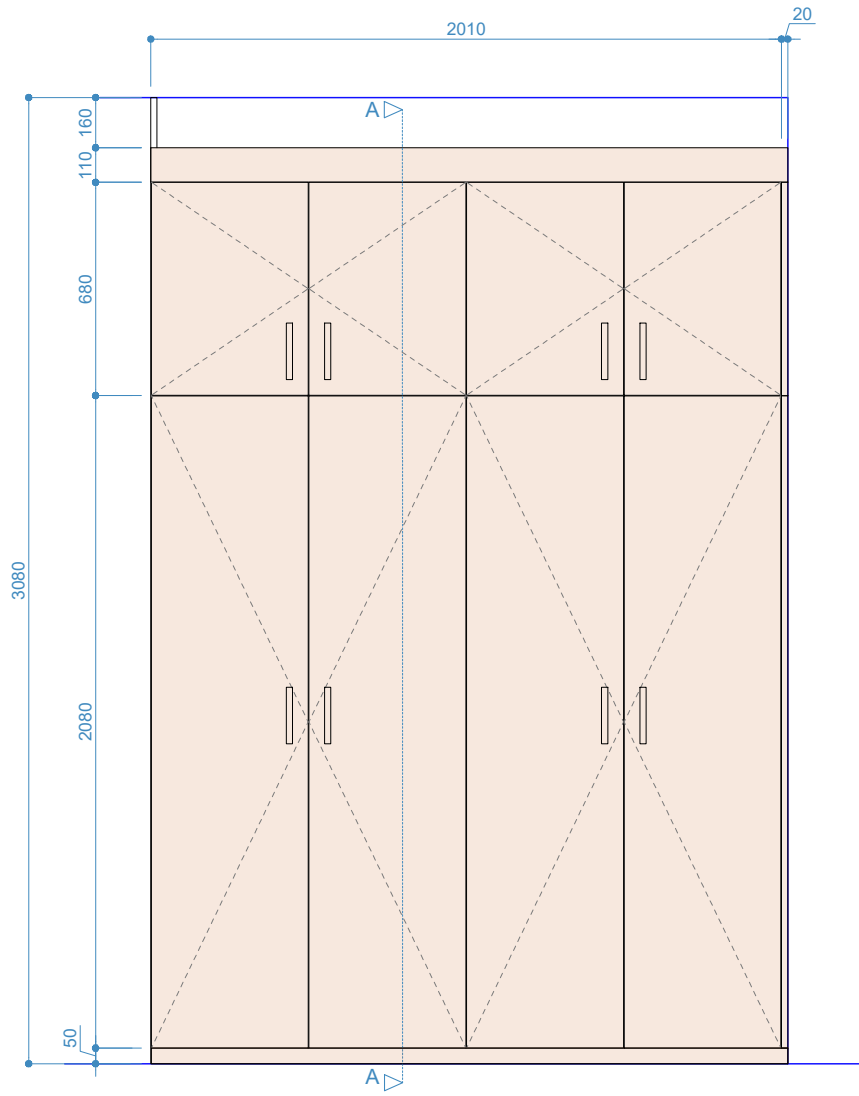

### GENERAL NOTES.

interieur:  
EGGER Nude terracotta - U830 ST9

exterieur:  
Chêne Moyen - 50% d'eau

LOT13 COLLETE  
DRESSING



Nom du Projet	
Adresse	

Designation / Type	
Lot	13
Date	17/05/2023
Page	13.3

REVISIONS	
Rev.	Date
Dessinateur	







GENERAL NOTES.

exterieur:  
MDF à peindre



PLAN

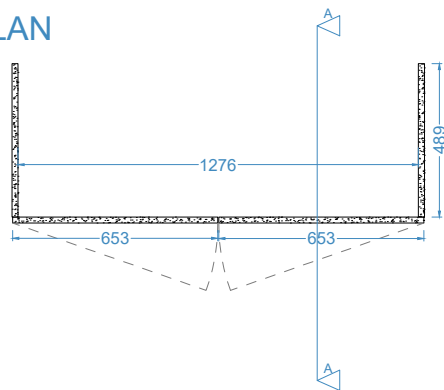

Coupe A-A

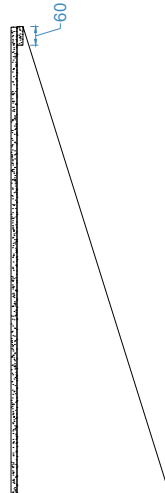

Elevations exterieures

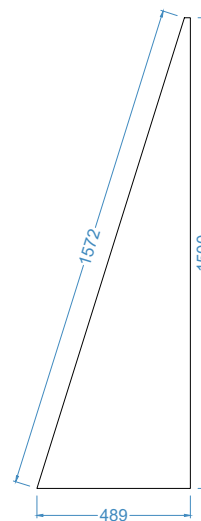
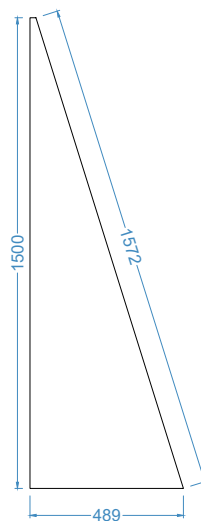
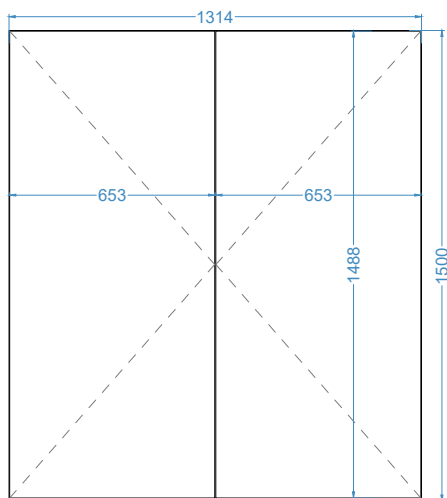

LOT15



Nom du Projet	
Adresse	

Designation / Type	
Lot	15
Date	17/05/2023
Page	15.1

REVISIONS	
Rev.	Date
Déssinateur	